

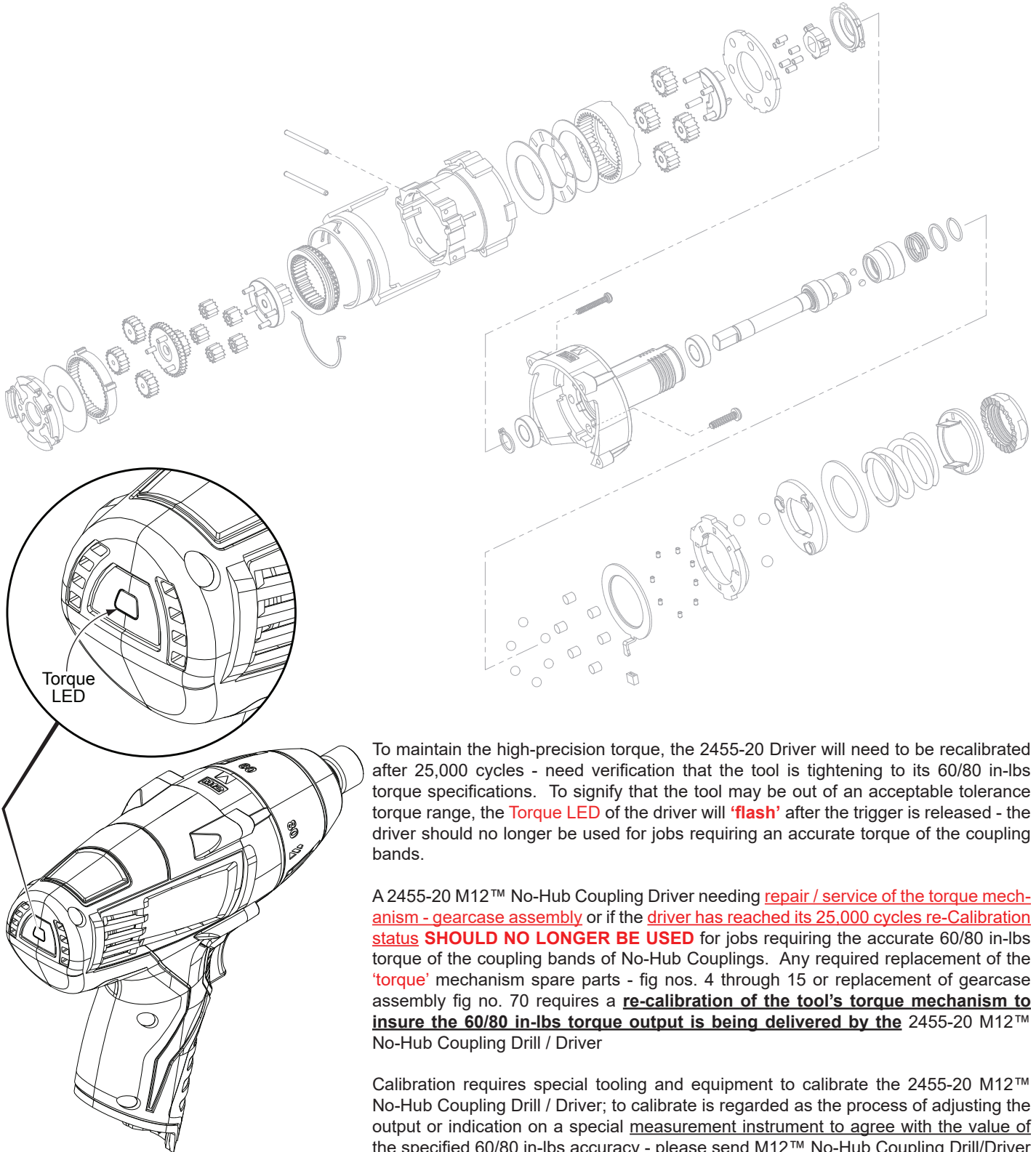

SERVICE PARTS LIST

BULLETIN NO.
54-06-2455

SPECIFY CATALOG NO. AND SERIAL NO. WHEN ORDERING PARTS		REVISED BULLETIN	DATE
Cordless M12™ No-Hub Coupling Driver-Drill			May 2019
CATALOG NO. 2455-20	STARTING SERIAL NO. C34A	WIRING INSTRUCTION SEE PAGE 4	



To maintain the high-precision torque, the 2455-20 Driver will need to be recalibrated after 25,000 cycles - need verification that the tool is tightening to its 60/80 in-lbs torque specifications. To signify that the tool may be out of an acceptable tolerance torque range, the **Torque LED** of the driver will **'flash'** after the trigger is released - the driver should no longer be used for jobs requiring an accurate torque of the coupling bands.

A 2455-20 M12™ No-Hub Coupling Driver needing repair / service of the torque mechanism - gearcase assembly or if the driver has reached its 25,000 cycles re-Calibration status **SHOULD NO LONGER BE USED** for jobs requiring the accurate 60/80 in-lbs torque of the coupling bands of No-Hub Couplings. Any required replacement of the **'torque'** mechanism spare parts - fig nos. 4 through 15 or replacement of gearcase assembly fig no. 70 requires a re-calibration of the tool's torque mechanism to insure the 60/80 in-lbs torque output is being delivered by the 2455-20 M12™ No-Hub Coupling Drill / Driver

Calibration requires special tooling and equipment to calibrate the 2455-20 M12™ No-Hub Coupling Drill / Driver; to calibrate is regarded as the process of adjusting the output or indication on a special measurement instrument to agree with the value of the specified 60/80 in-lbs accuracy - please send M12™ No-Hub Coupling Drill/Driver needing repair/service of the torque mechanism or if the driver has reached its 25,000 cycles to **Milwaukee Electric Tool Corporation - 13135 West Lisbon Road - Brookfield, Wisconsin 53005 - Attention: After-Sales Service.**

EXAMPLE:
 00 0 Component Parts (Small #)
 Are Included When Ordering
 The Assembly (Large #).

70 16 17 18 19 20
 22 24 26 47

69 16 17 18
 19 20

*Motor mount plate (47)
 shown here for
 reference only.



	Original Design 42-70-0055
	Improved Design 42-70-0058

M12™ tools utilize two different Housing Connection Clip designs depending on the Handle Set. See page two for details.

FIG.	PART NO.	DESCRIPTION OF PART	NO. REQ.
1	44-90-0970	Retaining Ring	(1)
4	-----	Adjustment Nut	(1)
5	-----	Lock Plate	(1)
6	-----	Spring	(1)
7	-----	Thrust Washer	(1)
8	-----	Ball Plate	(1)
9	-----	6mm Ball	(3)
10	-----	Spring Cam	(1)
11	-----	2 x 4mm Pin	(8)
12	-----	Clutch Washer	(1)
13	-----	Button	(1)
14	-----	5 x 5mm Pin	(6)
15	-----	5mm Ball	(6)
16	34-60-0725	External Retaining Ring	(1)
17	45-88-1881	Washer	(1)
18	40-50-1470	Spring	(1)
19	45-22-0825	Sleeve	(1)
20	02-02-0170	3.5mm Ball	(2)
22	-----	M4 ST Screw	(3)
24	06-82-7336	M4 x 3/4" Pan Hd. Plast. T-10	(4)
26	-----	Retaining Ring	(1)
47	-----	Motor Mount Plate	(1)
49	05-81-0205	Screw	(2)
50	05-90-0050	3mm Lock Washer	(2)
52	-----	12V Motor	(1)
57	31-76-0225	Forward/Reverse Shuttle	(1)

FIG.	PART NO.	DESCRIPTION OF PART	NO. REQ.
58	44-06-0175	LED Lens Cover	(1)
59	42-70-0055	Housing Connection Clip	(1)
60	06-82-6350	M4 x 16mm Pan Hd. Plast. T-10	(5)
61	10-15-2455	Warning Label	(1)
62	12-20-2455	Service Nameplate	(1)
68	31-12-0430	Cap Kit	(1)
69	45-22-0010	1/4" Sleeve Assembly	(1)
70	-----	Gearcase Assembly	(1)
71	23-30-1000	Motor Assembly	(1)
72	31-44-2073	Handle Assembly	(1)
73	23-66-2995	Switch and PCBA Assembly	(1)
74	42-55-2455	Carrying Case	(1)

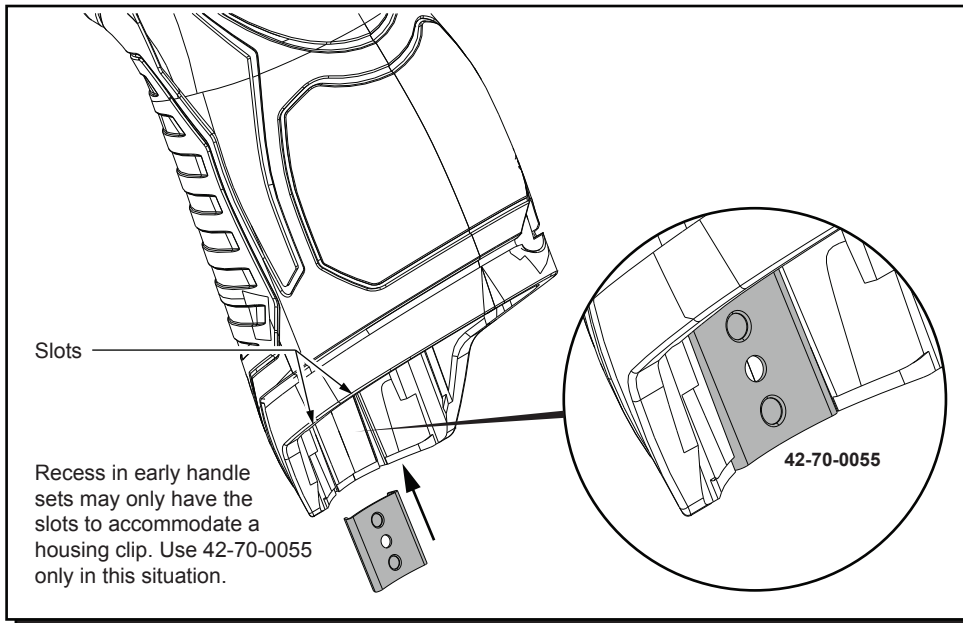

Early M12™ Handle Sets utilize **Housing Connection Clip No. 42-70-0055**. Install this clip design by aligning the side rails of the clip with the two slots in the handle set. Gently push into place with the aid of a small flat blade screwdriver or a similar instrument. Be sure that the clip is properly seated in both slots and that the clip is flush to sub-flush to the end of the handle set. To remove the clip, use the same small flat blade screwdriver or a similar instrument and push the clip out of the handle set. If the clip is loose or will not stay in place, a needle nose pliers can be used to gently bend/pinch the side rails of the clip. If the clip is damaged do not use, replace with a new 42-70-0055 housing clip.

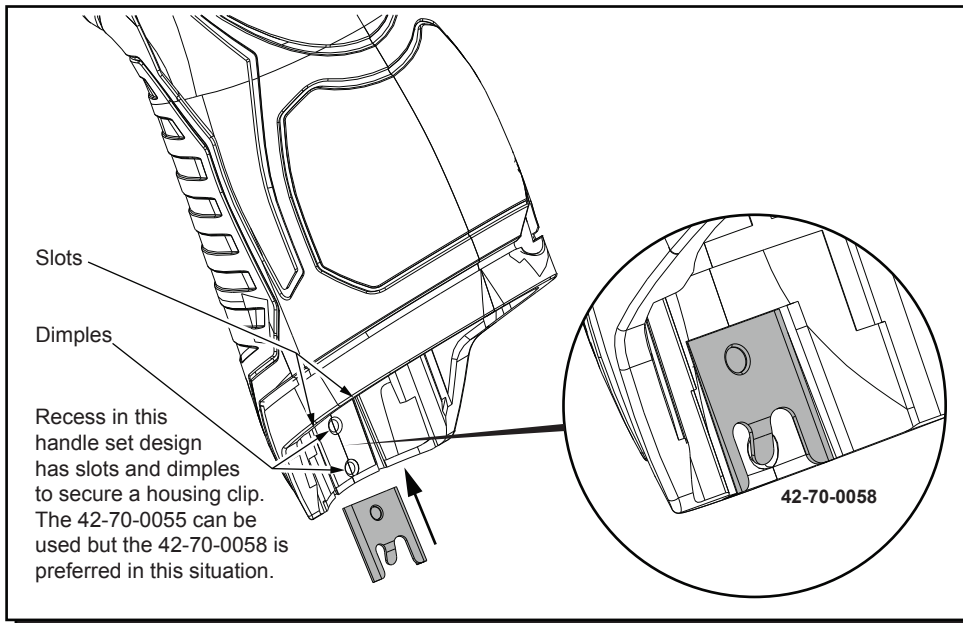

Updated M12™ Handle Sets utilize **Housing Connection Clips No. 42-70-0055 and 42-70-0058. (The 42-70-0058 is a preferred upgrade)**. Install this clip design by aligning the side rails of the clip with the two slots in the handle set. Gently push into place with the aid of a small flat blade screwdriver or a similar instrument. Be sure that the clip is properly seated in both slots and that the tab of the clip snaps down in the round dimpled cavity of the handle set. Be sure that the clip is flush to sub-flush to the end of the handle set. To remove the clip, use the same small flat blade screwdriver or a similar instrument and lift up on the clip tab while pushing the clip out of the handle set. Use a needle nose pliers to gently rebend the clip tab if necessary. If the tab on the clip is damaged during this process and is loose or will not stay in place, replace with a new 42-70-0058 clip.

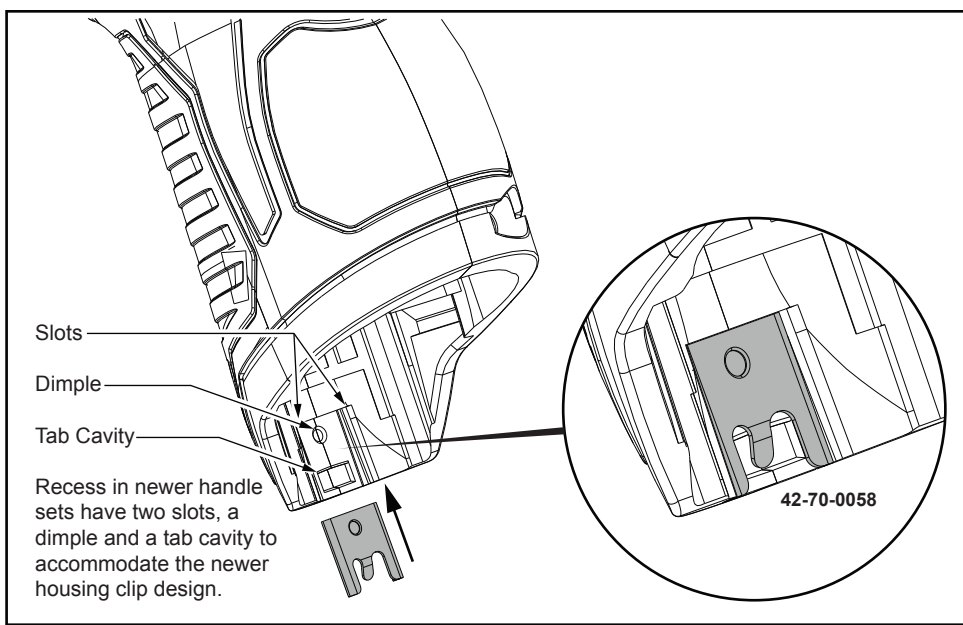

Newer M12™ Handle Sets utilize **Housing Connection Clip No. 42-70-0058**. Install this clip design by aligning the side rails of the clip with the two slots in the handle set. Gently push into place with the aid of a small flat blade screwdriver or a similar instrument. Be sure that the clip is properly seated in both slots and that the tab of the clip snaps down in the rectangular cavity of the handle set. Be sure that the clip is flush to sub-flush to the end of the handle set. To remove the clip, use the same small flat blade screwdriver or a similar instrument and lift the clip tab out of the cavity while pushing the clip out of the handle set. Use a needle nose pliers to gently rebend the clip tab if necessary. If the tab on the clip is damaged during this process and is loose or will not stay in place, replace with a new 42-70-0058 clip.

AS AN AID TO REASSEMBLY, TAKE NOTICE OF WIRE ROUTING AND POSITION IN WIRE GUIDES AND TRAPS WHILE DISMANTLING TOOL

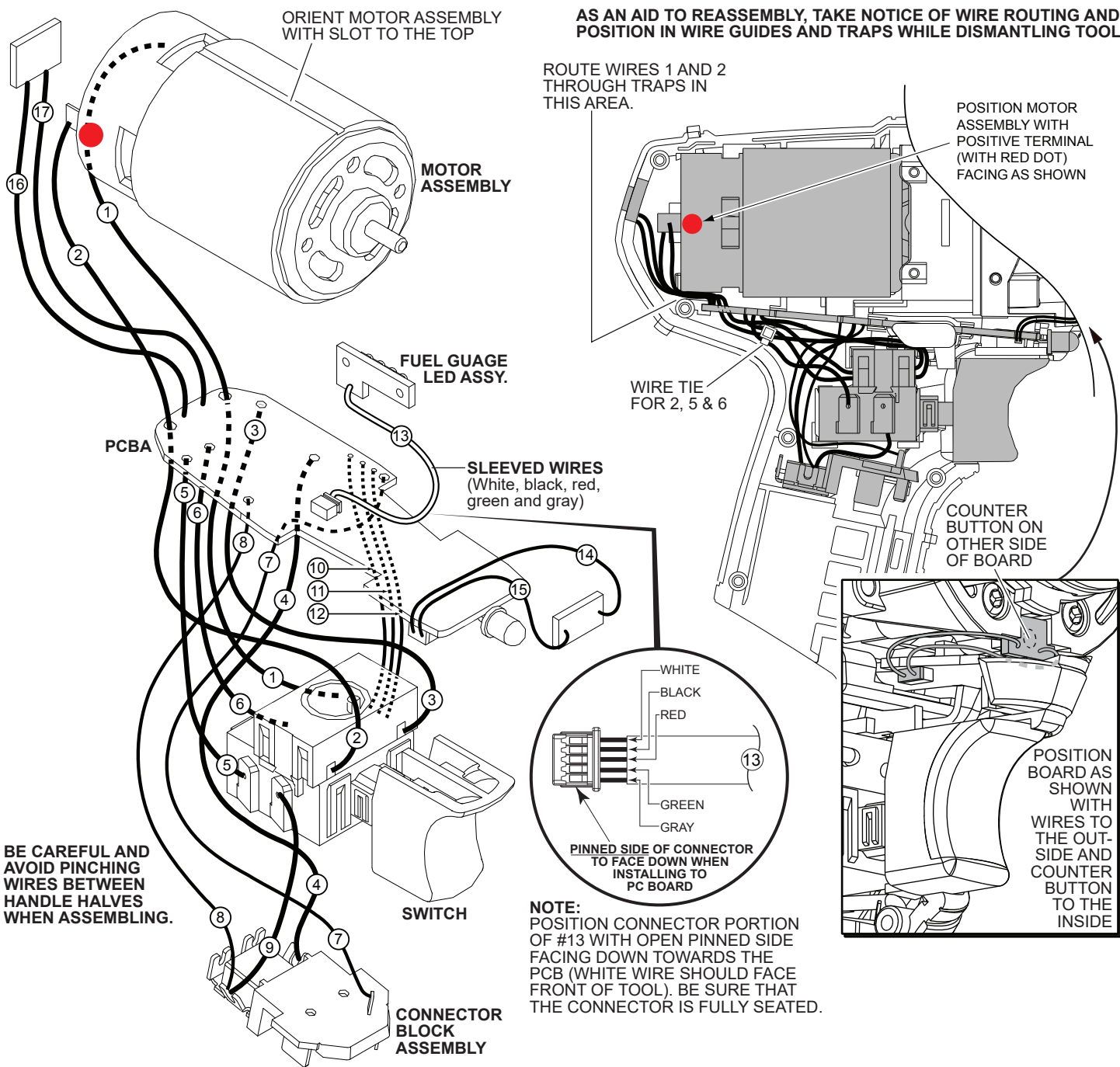

WIRING SPECIFICATIONS

Wire No.	Wire Color	Origin or Gauge	Length	Terminals, Connectors and 1 or 2 End Wire Preparation
1	Black	23-30-1000	-----	Component of the motor assembly.
2	Red	23-30-1000	-----	Component of the motor assembly.
3	White	23-66-2995	-----	Component of the switch / PCBA assembly.
4	Black	23-66-2995	-----	Component of the switch / PCBA assembly.
5	Black	23-66-2995	-----	Component of the switch / PCBA assembly.
6	Red	23-66-2995	-----	Component of the switch / PCBA assembly.
7	White	23-66-2995	-----	Component of the switch / PCBA assembly.
8	Red	23-66-2995	-----	Component of the switch / PCBA assembly.
9	Red	23-66-2995	-----	Component of the switch / PCBA assembly.
10	Yellow	23-66-2995	-----	Component of the switch / PCBA assembly.
11	Blue	23-66-2995	-----	Component of the switch / PCBA assembly.
12	Black	23-66-2995	-----	Component of the switch / PCBA assembly.
13	Sleeve	23-66-2995	-----	Component of the switch / PCBA assy. / fuel gauge LED.
14	Red	23-66-2995	-----	Component of the switch / PCBA assembly.
15	White	23-66-2995	-----	Component of the switch / PCBA assembly.
16	Blue	23-66-2995	-----	Component of the switch / PCBA assembly.
17	Black	23-66-2995	-----	Component of the switch / PCBA assembly.